

Ballinguiroe & Tankardstown GWS Co-Op Society Ltd.,
C/O Tom Jackson,
Ballyshonack,
Kildorrery,
Co. Cork.

2nd October, 2024

REF: D/259/24
LOCATION: Quitrent, Kildorrery, Co. Cork.

**RE: DECLARATION OF EXEMPTED DEVELOPMENT UNDER SECTION 5 OF THE
PLANNING & DEVELOPMENT ACT 2000 - 2010.**

Dear Sir,

On the basis of the information submitted by you on 10th & 27th September, 2024 the Planning Authority, having considered whether the installation of a ground mounted, 15.2KW solar PV system with a total surface area of 71.7sqm used to power a Community Group Water Scheme at **Quitrent, Kildorrery, Co. Cork** is or is not development or is or is not exempted development, has declared that it is **exempted development**.

Reason for Decision

The Planning Authority in considering this referral, had particular regard to:

- Sections 2(1), 3(1) and 4(1)(a) of the Planning and Development Act 2000 (as amended)
- Article 9(1)(a) of the Planning and Development Regulations, 2001, as amended
- The Planning and Development Act 2000 (Exempted Development) (No. 3) Regulations 2022 and the supporting Planning and Development (Solar Safeguarding Zone) Regulations 2022.
- The plans and particulars received by the Planning Authority on 10th September, 2024.

And Whereas the Planning Authority hereby concludes that

The installation of a ground mounted, 15.2KW Solar PV system with a total surface area of 71.7sqm used to power a Community Group Water Scheme constitutes 'works' and 'development' as defined in Sections 2 and 3 of the Planning and Development Act. The development comes within the scope of the exemption for PV Solar arrays provided by The Planning and Development Act 2000 (Exempted Development) (No. 3) Regulations 2022 and the supporting Planning and Development (Solar Safeguarding Zone) Regulations 2022 that came into effect on 5th October, 2022 and complies with

the relevant conditions and limitations. It is also considered that these exemptions are not restricted by the terms of Article 9(1)(a)(viiB).

On this basis it is considered that the proposed development at **Quitrent, Kildorrery, Co. Cork** constitutes **development and is exempted development**.

This exemption does NOT itself empower a person to carry out a development unless that person is legally entitled to do so.

Please note that under Section 5 Subsection 3(a) where a declaration is issued under this section, any person issued with a declaration under subsection 2(a) may, on payment to the Board of such fee as may be prescribed, refer a declaration for review by the Board within 4 weeks of the date of the issuing of the declaration.

Yours faithfully,



**KEVIN O'REGAN,
SENIOR EXECUTIVE OFFICER,
PLANNING DEPARTMENT.**

In order to process your query, it may be necessary for Cork County Council to collect Personal information from you. Such information will be processed in line with our privacy statement which is available to view at <https://www.corkcoco.ie/privacy-statement-cork-county-council>

SECTION 5 DECLARATION – PLANNER’S REPORT

File Reference: D/259/24

Description: Whether the installation of a ground mounted, 15.2KW Solar PV system with a total surface area of 71.7sqm used to power a Community Group Water Scheme is or is not development or is or is not exempted development.

Applicant: Ballinguiroe & Tankardstown GWS Co-Op

Location: Quitrent, Kildorrery, Co. Cork

Date: 30th September 2024

SUMMARY OF RECOMMENDATION

It is concluded that the installation of a ground mounted, 15.2KW Solar PV system with a total surface area of 71.7sqm used to power a Community Group Water Scheme constitutes ‘works’ and ‘development’ as defined in Sections 2 and 3 of the Planning and Development Act. The development comes within the scope of the exemption for PV Solar arrays provided by The Planning and Development Act 2000 (Exempted Development) (No. 3) Regulations 2022 and the supporting Planning and Development (Solar Safeguarding Zone) Regulations 2022 that came into effect on 5 October 2022 and complies with the relevant conditions and limitations. It is also considered that these exemptions are not restricted by the terms of Article 9(1)(a)(viiB).

On this basis it is considered that the proposed development **is development and is exempted development.**

PURPOSE OF REPORT

Under Section 5 of the Planning and Development Act, 2000 (as amended), if any question arises as to what, in any particular case, is or is not development and is or is not exempted development within the meaning of the Act, any person may, on payment of the prescribed fee, request in writing from the relevant planning authority a declaration on that question, and that person shall provide to the planning authority any information necessary to enable the authority to make its decision on the matter.

SITE LOCATION

The subject site is located in the rural townland of Ballyshonock approx. 2km northwest of Kildorrery. There are no scenic routes or protected structures within close proximity of the site. There are no recorded Sites and Monuments within the surrounding area. The subject site does not lie within any designated Natura sites. The Blackwater River SAC (Site Code 2170) is located approx. 4.4km to the southwest. The subject site lies within the AA screening zone for the Blackwater River SAC (Site Code 2170). At present, there is a well and a pump house constructed on site which houses the associated plant and electrical equipment to run the group water scheme. There are two no. pedestrian accesses to the subject site.

SUBJECT DEVELOPMENT

The application documents state that the Ballinguiroe & Tankardstown Group Water Scheme Co-Operative Society Limited is a community owned and ran water supply. In order to reduce the carbon emissions and running costs, the applicant conducted an energy audit. This energy audit recommended that they install solar PV array on site to supply electricity to the pump house and associated plant and electrical equipment to run the group water scheme.

The question to which this Section 5 Declaration relates is whether the installation of a ground mounted,15.2KW Solar PV system with a total surface area of 71.7sqm used to power a Community Group Water Scheme is or is not development or is or is not exempted development.

PLANNING HISTORY

A review of the Council's Planning Enquiry System shows there have been no recent planning applications made in respect of the subject site.

LEGISLATIVE CONTEXT

Planning and Development Act, 2000

Section 3(1) of the Act states the following in respect of 'development': "In this Act, 'development' means, except where the context otherwise requires, the carrying out of any works on, in, over or under land or the making of any material change in the use of any structures or other land."

Section 2(1) of the Act states the following in respect of 'works': "Any act or operation of construction, excavation, demolition, extension, alteration, repair or renewal..."

Section 4(1) sets out various forms and circumstances in which development is exempted development for the purposes of the Act. Section 4 (1) (a) states that development consisting of the use of any land for the purposes of agriculture and development consisting of the use for that purpose of any building occupied together with land so used.

Section 4 (2)(a) of the Act enables certain classes of development to be deemed exempted development by way of regulation.

Section 4(4) states that notwithstanding paragraph (a) of subsection (1) and any regulations under subsection (2), development shall not be exempted development if an environmental impact assessment or an appropriate assessment is required.

Planning and Development Regulations, 2001 as amended.

Article 6(3) states: Subject to Article 9, in areas other than a city, a town or an area specified in section 19 (1) (b) of the Act or the excluded areas as defined in section 9 of the Local Government (Reorganisation) Act, 1985 (No.7 of 1985), development of a class specified in Column 1 of Part 3 of Schedule 2 shall be exempted development for the purposes of the Act, provided that such development complies with the conditions and limitations specified in column 2 of the said Part 3 opposite the mention of that class in the said column 1.

The Planning and Development Act 2000 (Exempted Development) (No. 3) Regulations 2022 and the supporting Planning and Development (Solar Safeguarding Zone) Regulations 2022 that came into effect on 5 October 2022.

Schedule 2, Part 3 – Exempted Development

Class 61

The placing or erection on a roof, or within the curtilage, or on a roof of any ancillary buildings within the curtilage, of the following buildings or sites of a solar photo-voltaic and/or solar thermal collector installation:

- (i) an educational building,
- (ii) health centre or hospital,
- (iii) recreational or sports facility,
- (iv) place of worship,
- (v) community facility or centre,
- (vi) library,
- (vii) sites for the provision of gas, electricity, telecommunications services or water supplies or wastewater services operated by a statutory undertaker.

1. Where such development is located within a solar safeguarding zone, the total aperture area of any solar photo-voltaic and/or solar thermal collector panels, taken together with any other such panels previously placed on a roof, shall not exceed 300 square metres.

2. Where such development is located within a solar safeguarding zone, the planning authority for the area shall be notified in writing no later than 4 weeks after the commencement of such development and such notification shall include details regarding the location and scale of the development.

3. The distance between the plane of the roof and the solar photo-voltaic or solar thermal collector panels shall not exceed 1.2 metres in the case of a flat roof or 15cm in any other case.

4. The solar photo-voltaic or solar thermal collector panels shall be a minimum of 2 metres in the case of a flat roof or 50cm in any other case from the edge of the roof on which it is mounted.

5. Any ancillary equipment associated with solar photo-voltaic or solar thermal collector panels shall not be placed or erected on a wall or any roof that is not a flat roof.

6. The height of any ancillary equipment associated with solar photo-voltaic or solar thermal collector panels on a flat roof shall not exceed 1.6 metres above roof level.

7. Any ancillary equipment associated with solar photo-voltaic or solar thermal collector panels on a flat roof shall be a minimum of 2 metres from the edge of the roof on which it is mounted.

8. Any free-standing solar photo-voltaic or solar thermal collector installation shall not be placed or erected forward of the front wall of the building or site.

9. The total aperture area of any free-standing solar photo-voltaic and solar thermal collector panels taken together with any other such existing free-standing panels shall not exceed 75 square metres.

10. The height of any free-standing solar photo-voltaic or solar thermal collector installation shall not exceed 2.5 metres at its highest point above ground level.

11. The placing or erection of a solar photo-voltaic or solar thermal collector installation on any wall shall not be exempted development.

12. The placing or erection of any free-standing solar photo-voltaic or solar thermal collector installation within an Architectural Conservation Area shall only be exempted development if those works would not materially affect the character of the area.

13. No sign, advertisement or object not required for the functioning or safety of the solar photo-voltaic or solar thermal collector installation shall be attached to or exhibited on such installation.

14. Development under this Class shall only be exempted development where the solar photo-voltaic or solar thermal collector installation is primarily used for the provision of electricity or heating for use within the curtilage of the building or site and shall not be considered a change of use for the purposes of the Act.

15. Development under this Class which causes hazardous glint and/or glare shall not be exempted development and any solar photo-voltaic or solar thermal collector panels which are causing hazardous glint and/or glare shall either be removed or be covered until such time as a mitigation plan to address the hazardous glint and/or glare is agreed and implemented to the satisfaction of the Planning Authority.

Restrictions on exemption by virtue of Article 9(1)(a) of the Planning and Development Regulations 2001 (as amended)

Article 9 (1) (a) provides that certain development to which Article 6 relates (i.e. exempted development) shall not be exempted in various circumstances. Article 9(1) states that: Development to which Article 6 relates shall not be exempted development for the purposes of the Act – (a) if the carrying out of such development would:

(viiB) comprise development in relation to which a planning authority or An Bord Pleanála is the competent authority in relation to appropriate assessment and the development would require an appropriate assessment because it would be likely to have a significant effect on the integrity of a European site.

ASSESSMENT

The application documents state that the Ballinguiroe & Tankardstown Group Water Scheme Co-Operative Society Limited is a community owned and ran water supply. In order to reduce the carbon emissions and running costs, the applicant conducted an energy audit. This energy audit recommended that they install solar PV at the site.

The question to which this Section 5 Declaration relates is whether the installation of a ground mounted, 15.2KW Solar PV system with a total surface area of 71.7sqm used to power a Community Group Water Scheme is or is not development or is or is not exempted development.

Is or is not development?

Development is defined, under Section 3(1) of the Planning and Development Act, 2000 (as amended), as “the carrying out of works on, in, over or under land...” Works are defined, under Section 2(1) of this Act, as including “any act or operation of construction, excavation, demolition, extension.

The installation of a ground mounted, 15.2KW Solar PV system with a total surface area of 71.7sqm used to power a Community Group Water Scheme consists of the carrying out of ‘works’ and therefore **constitute ‘development’**, as defined in Section 3 of the Planning and Development Act 2000, as amended.

Is or is not exempted development?

The subject development is within the curtilage of a ‘community facility’ (the group water scheme) and this is one of the classes of exemption Under Class 61 of The Planning and Development Act 2000 (Exempted Development) (No. 3) Regulations 2022 and the supporting Planning and Development (Solar Safeguarding Zone) Regulations 2022. In terms of compliance with the associated limitations:

1. Where such development is located within a solar safeguarding zone, the total aperture area of any solar photo-voltaic and/or solar thermal collector panels, taken together with any other such panels previously placed on a roof, shall not exceed 300 square metres. **(Not located within a solar safeguarding zone).**
2. Where such development is located within a solar safeguarding zone, the planning authority for the area shall be notified in writing no later than 4 weeks after the commencement of such development and such notification shall include details regarding the location and scale of the development. **(Not located within a solar safeguarding zone).**
3. The distance between the plane of the roof and the solar photo-voltaic or solar thermal collector panels shall not exceed 1.2 metres in the case of a flat roof or 15cm in any other case. **(N/A as ground mounted array).**
4. The solar photo-voltaic or solar thermal collector panels shall be a minimum of 2 metres in the case of a flat roof or 50cm in any other case from the edge of the roof on which it is mounted. **(N/A as ground mounted array).**
5. Any ancillary equipment associated with solar photo-voltaic or solar thermal collector panels shall not be placed or erected on a wall or any roof that is not a flat roof. **(N/A as ground mounted array).**
6. The height of any ancillary equipment associated with solar photo-voltaic or solar thermal collector panels on a flat roof shall not exceed 1.6 metres above roof level. **(N/A as ground mounted array).**
7. Any ancillary equipment associated with solar photo-voltaic or solar thermal collector panels on a flat roof shall be a minimum of 2 metres from the edge of the roof on which it is mounted. **(N/A as ground mounted array).**
8. Any free-standing solar photo-voltaic or solar thermal collector installation shall not be placed or erected forward of the front wall of the building or site. **(N/A as ground mounted array in agricultural field to rear of Group Water Supply Scheme and existing pump house).**

9. The total aperture area of any free-standing solar photo-voltaic and solar thermal collector panels taken together with any other such existing free-standing panels shall not exceed 75 square metres. **The total area of 71.7sqm is below threshold.**

10. The height of any free-standing solar photo-voltaic or solar thermal collector installation shall not exceed 2.5 metres at its highest point above ground level. **The drawings submitted an unsolicited further information show that the proposed height of the panels will not exceed 2.5m in height – proposed height of 2.44m shown.**

11. The placing or erection of a solar photo-voltaic or solar thermal collector installation on any wall shall not be exempted development. **N/A as ground mounted array.**

12. The placing or erection of any free-standing solar photo-voltaic or solar thermal collector installation within an Architectural Conservation Area shall only be exempted development if those works would not materially affect the character of the area. **N/A as not in an ACA.**

13. No sign, advertisement or object not required for the functioning or safety of the solar photo-voltaic or solar thermal collector installation shall be attached to or exhibited on such installation. **No advertisements/signs proposed.**

14. Development under this Class shall only be exempted development where the solar photo-voltaic or solar thermal collector installation is primarily used for the provision of electricity or heating for use within the curtilage of the building or site and shall not be considered a change of use for the purposes of the Act. **The proposed Solar PV array will be used for the power the pump house equipment associated with the Group Water Scheme on site.**

15. Development under this Class which causes hazardous glint and/or glare shall not be exempted development and any solar photo-voltaic or solar thermal collector panels which are causing hazardous glint and/or glare shall either be removed or be covered until such time as a mitigation plan to address the hazardous glint and/or glare is agreed and implemented to the satisfaction of the Planning Authority. **No issue foreseen.**

Having reviewed the application documents and drawings, I am satisfied that the conditions and limitations associated with the Class 61 would not be breached or exceeded. I am therefore satisfied that the proposed PV Solar array would accord with the requirements of Class 61.

In relation to restrictions on exemptions by virtue of Article 9(1)(a) of the Planning and Development Regulations 2001 (as amended) I note the following:

Article 9 (1) (a) provides that certain development to which Article 6 relates (i.e. exempted development) shall not be exempted in various circumstances. Article 9(1) states that: Development to which Article 6 relates shall not be exempted development for the purposes of the Act – (a) if the carrying out of such development would:

(viiB) comprise development in relation to which a planning authority or An Bord Pleanála is the competent authority in relation to appropriate assessment and the development would require an appropriate assessment because it would be likely to have a significant effect on the integrity of a European site.

EIAR and SUB-THRESHOLD EIAR

Projects which are likely to have significant effects on the environment are identified in Annex I and Annex II of the EIA Directive, which have been transposed into Irish legislation by Part I and Part II, Schedule 5 of the Planning and Development Regulations 2001 (as amended). Solar PV panels are not of a Class of development listed under Part 1 or 2 (Schedule 5) of the Planning and Development Regulations 2001. As such, Environmental Impact Assessment does not apply in this case. Thus, the provisions of Section 4(4) of the Planning and Development Act 2000 (as amended) are not relevant.

Having regard to the contents of Article 103 (as amended by Article 14 of the Planning and Development (Amendment) (No3) Regulations 2011) and Schedule 7 of the Planning and Development Regulations 2001 (as amended) it is considered that the proposed development by reason of its nature, scale and location would not be likely to have significant effects on the environment. Accordingly, it is considered that a sub-threshold EIAR is not required to be submitted.

APPROPRIATE ASSESSMENT

As regards Appropriate Assessment Section 4(4) of the Planning and Development Act restricts exemption where development needs an appropriate assessment. In view of the scale and the nature and extent of the development, together with the separation and hydrological distances from the nearest European sites (4.4km to south), it is considered that no appropriate assessment issues arise. It is considered that the development would not be likely to have a significant effect individually or in combination with other plans or projects on a European site. Appropriate Assessment is not therefore required, and the provisions of Section 4(4) of the Planning and Development Act 2000 (as amended) are not relevant. The Ecology Department confirmed that "It's sufficiently distant from the SAC and small enough to not be an issue".

CONCLUSION

Having regard to:

- the particulars received by the Planning Authority on 10th September 2024,
- Section 2(1) of the Planning and Development Act, 2000, as amended,
- Section 3(1) of the Planning and Development Act, 2000,
- Section 4(1)(a) of the Planning and Development Act, 2000, as amended,
- The Planning and Development Act 2000 (Exempted Development) (No. 3) Regulations 2022 and the supporting Planning and Development (Solar Safeguarding Zone) Regulations 2022.
- Article 9(1)(a) of the Planning and Development Regulations 2001 (as amended).

It is concluded that the installation of a ground mounted, 15.2KW Solar PV system with a total surface area of 71.7sqm used to power a Community Group Water Scheme constitutes 'works' and 'development' as defined in Sections 2 and 3 of the Planning and Development Act. The development comes within the scope of the exemption for PV Solar arrays provided by The Planning and Development Act 2000 (Exempted Development) (No. 3) Regulations 2022 and the supporting Planning and Development (Solar Safeguarding Zone) Regulations 2022 that came into effect on 5 October 2022 and complies with the relevant conditions and limitations. It is also considered that these exemptions are not restricted by the terms of Article 9(1)(a)(viiB).

On this basis it is considered that the proposed development **is development and is exempted development.**



Janet Payne
Executive Planner
30th September 2024

The above report and recommendation is noted and endorsed.

I concur with the conclusion that the proposed development is **development and is exempted development.**

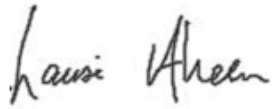

Louise Ahern
A/Senior Executive Planner
02/10/2024

Tracy OCallaghan

From: Jamie Field [Climeaction]
Sent: Friday 27 September 2024 15:34
To: PlanningInfo
Cc: Tom Jackson; Róisín Dowd Smith Unsolicited
Subject: Information for D25924 - GWS Ballinguiroe
Attachments: SUNFIXINGS Layout JP508.A NFGWS.pdf

CAUTION FROM CORK COUNTY COUNCIL IT SECURITY: This email originated from outside of the organisation. Do not click links or open attachments unless you recognise the sender and know the content is safe. If in doubt, please contact itservicedesk@corkcoco.ie / ext 5700 or phishingreport@corkcoco.ie to report the e-mail as suspicious

Hi Tracy,

As discussed on the call, please see the unsolicited information for the application D/25924. As part of this solar installation – I would like to confirm that the final height of the solar panels from the ground to the highest point of the panels will be less than 2.5 metres. Please see the attached drawing showing the proposed arrangement for this installation.

Any questions please let me know.

Best regards,

Jamie Field



Jamie Field | Industrial Energy Consultant

a: Climeaction | 11 South Mall, Cork City, T12 CYF7 | Ireland
a (US): Climeaction Ltd | One Marina Park Drive, Seaport
| Boston, MA, | USA



Certified

Corporation

This company is committed to accountability, transparency, and continuous improvement.

THE TIME FOR ACTION IS NOW

Join us in making a real impact on Climate Change through a practical, results driven approach with a return on investment

NB: I don't expect you to respond to my emails outside of your working hours. At Climeaction we respect flexible working schedules so please respond when you are working.

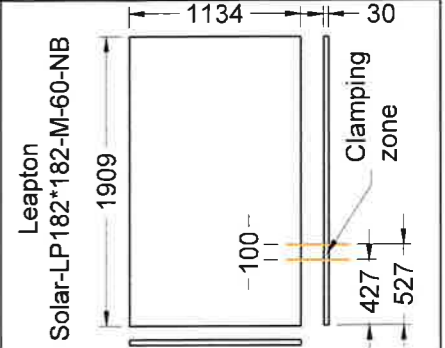
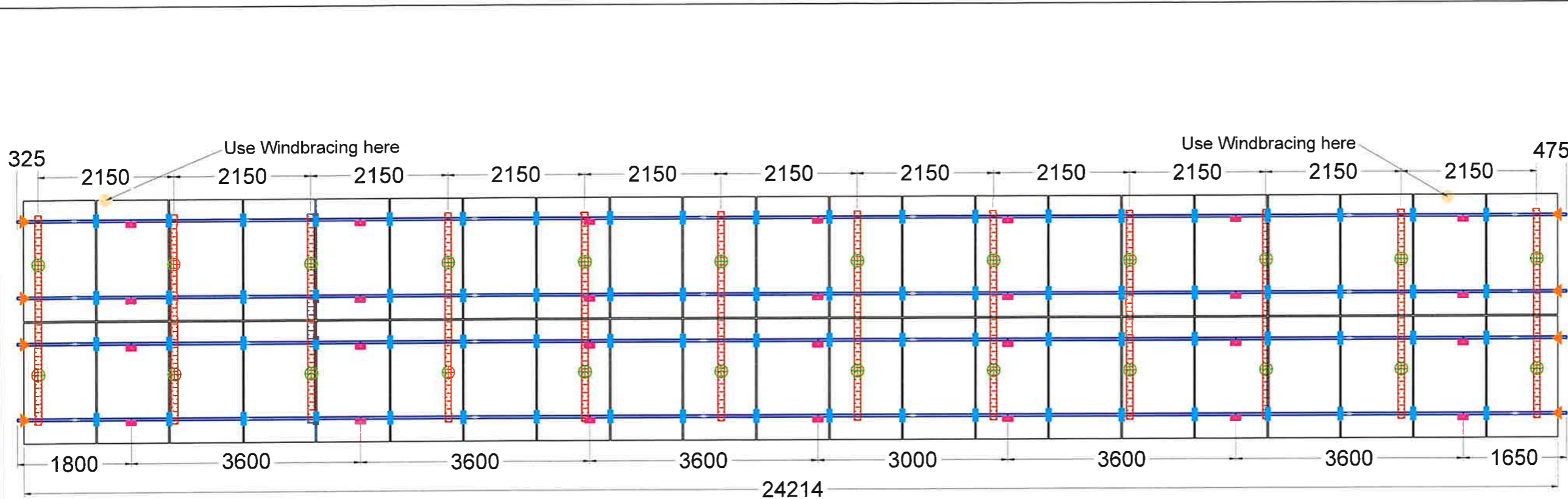

Legend:

□	Substructure	○	Module
▶	Array Form	⊕	Ground Level
■	Substructure	+	Ground Level
+	Crossing		
—	Wires		
—	Wires		
—	Wires		
—	Wires		
—	Wires		

Notes:
42 modules

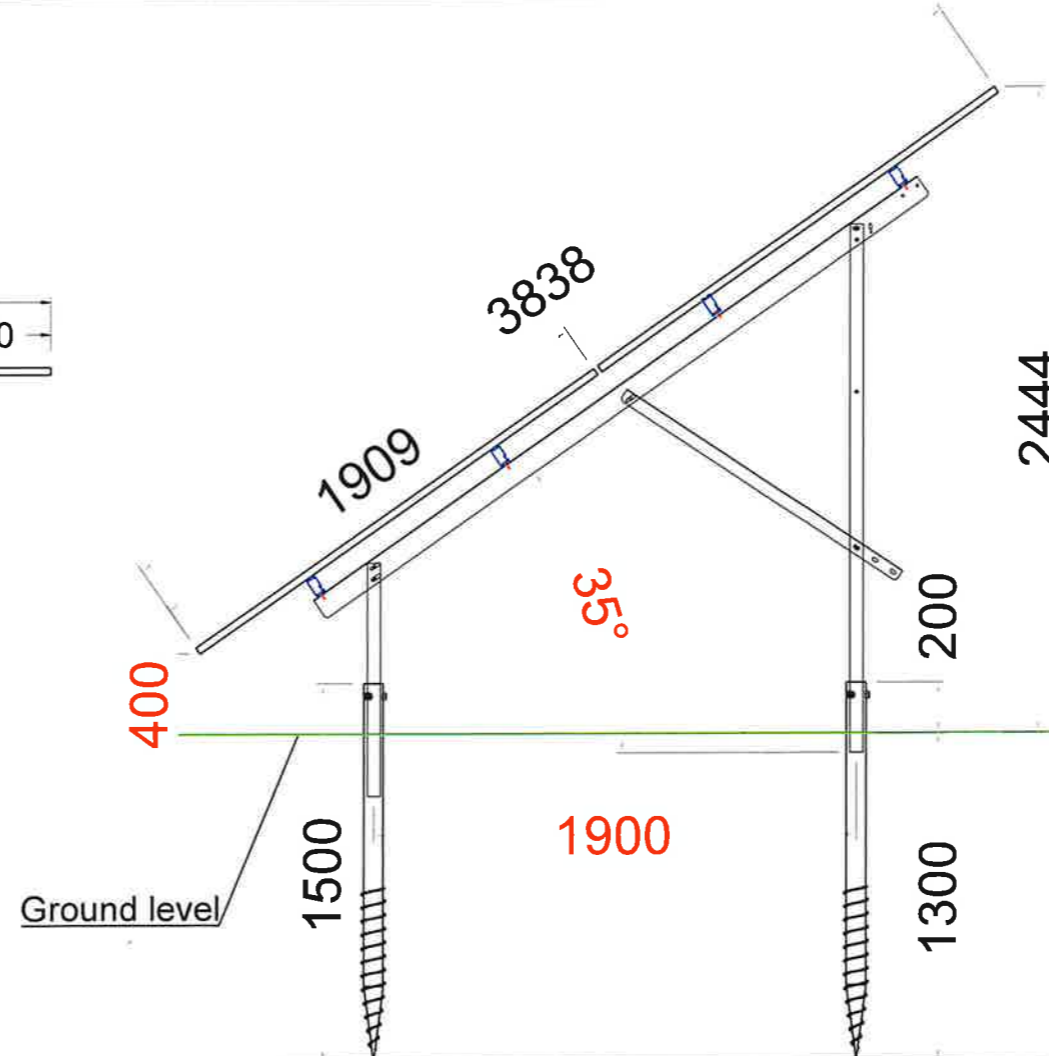
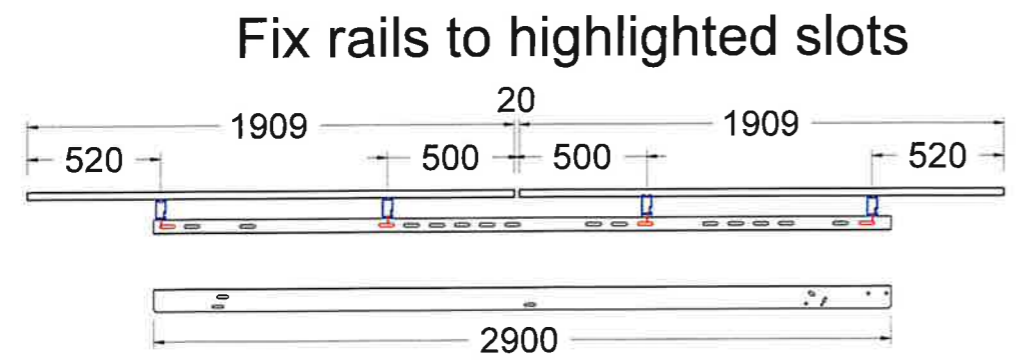

CONFIDENTIAL PROPOSAL ONLY

Project: V-TRIP
System: V-TRIP
Mod. Dimensions: 1920x1134x30mm
Base Rail: 40x80
Module Rail: 40x80
Date: 27/06/2024
Dwn: LAR, PC, CLK, CKD, JP



SUNFIXINGS is a registered company in the United Kingdom. All rights reserved. No part of this publication may be reproduced, stored in a retrieval system, or transmitted, in any form or by any means, without the prior written permission of Sunfixings Ltd. This drawing is a proposal only and does not constitute an offer of any product or service. Sunfixings Ltd is not responsible for any errors or omissions in this drawing. The use of this drawing for any other purpose is prohibited. Sunfixings Ltd is not responsible for any damage or loss resulting from the use of this drawing. The use of this drawing is at the user's own risk. Sunfixings Ltd is not responsible for any damage or loss resulting from the use of this drawing. The use of this drawing is at the user's own risk.



CORK COUNTY COUNCIL APPLICATION FOR SECTION 5 DECLARATION OF EXEMPTION

APPLICANT CHECKLIST

(Please tick ✓)

- 4 No. Copies of Application Form:**
- 1 No. Copy of Contact Details:**
- 4 No. Copies 6" O.S. Maps:**
- 4 No. Copies 25" O.S. Maps:**
- 4 No. Copies of Site Layout Plan:**
- 4 No. Copies Scaled Drawings of Development:**
- €80 Application Fee:**

Planning Department

10 SEP 2024

Cork County Council
County Hall
Cork.

FOR OFFICE USE ONLY

Receipt No.	PCL-0002407
Cash/Cheque/ Credit Card	Cheque
Date	10/09/2024
Declaration Ref. No.	D/259/24

DATE STAMP HERE

You should make sure that you are satisfied that any information/documentation that you submit is appropriate to be viewed by the public. Please do not submit any information that you do not want 3rd parties to view.

In the case of a Declaration of Exemption for Land Reclamation, the following additional information is required:

- A copy of the details submitted to the Council's Environment Department (Inniscarra) for a Waste Licence Permit
- Correspondence from Teagasc (detailing how the land reclamation would benefit the land in question for agricultural purposes)
- Details of existing and proposed levels
- Details of fill material and duration of fill.

DATA PROTECTION

The planning process is an open and public one. In that context, all applications for Declarations of Exemption are made available for public inspection.

Personal information collected by Cork County Council is done so in order for us to process your application for a Section 5 Declaration of Exemption. Legally we can process this information as it is necessary for us to comply with our statutory/legal obligations. The protection of our personal data is a key priority for the Council and your data will be processed in line with our Privacy policy which is available at <http://www.corkcoco.ie/Privacy-Policy> or hardcopy from our offices at County Hall, Carrigrohane Road, Cork, Ireland. Should you have any questions about our privacy policy or the information we hold about you, please contact us by email to dpo@corkcoco.ie or write to us at Data Protection Officer, Cork County Council, County Hall, Carrigrohane Road, Cork, Ireland.

1. NAME OF APPLICANT: (ADDRESS TO BE SUPPLIED AT QUESTION A – CONTACT DETAILS)

Ballinguiroe & Tankardstown Group Water Scheme Co-Operative Society Limited.
C/O Tom Jackson, Chairman.

2. POSTAL ADDRESS OF LAND OR STRUCTURE FOR WHICH DECLARATION OF EXEMPTION IS SOUGHT:

Quitrent, Kildorrery, Co. Cork.

3. QUESTION/DECLARATION DETAILS:

Please state the specific question for which a Declaration of Exemption is sought

Note: Only works listed and described under this section will be assessed under the Section 5 Declaration of Exemption

Ballinguiroe & Tankardstown Group Water Scheme Co-Operative Society Limited is a community owned and ran water supply. In order to reduce our carbon emissions and running costs, we conducted an energy audit. This energy audit recommended we install solar PV at the site.

We wish to clarify the planning requirements for a 15.2 kw solar PV system, 54 panels, ground mounted with a total surface area of 71.7 m2 which is below the 75m2 limit.

We seek to check whether this proposal constitutes development* or exempted development* as this project may be deemed as development but exempted development under The Planning and Development Act 2000 (Exempted Development) (No. 3) Regulations 2022 and the supporting Planning and Development (Solar Safeguarding Zone) Regulations 2022 that came into effect on 5 October 2022.

The site is located on/next to a river approx. 4.4km north of the closest SAC which we would seek to check if it is sufficiently distant from the SAC and small enough to not be an issue.

Under "Restrictions on exemption by virtue of Article 9(1)(a) of the Planning and Development Regulations 2001 (as amended)", Class 61 highlights 15 no. limitations to relevant exemptions which we believe we are fully compliant with since this is a community facility and the solar array is within the curtailage of the property.

We are also submitting additional drawings to provide the layout details, positioning and surrounding area information as part of this submission.

Planning Department

10 SEP 2024

Cork County Council
County Hall
Cork

4. APPLICATION DETAILS:

Answer the following if applicable. Note: Floor areas are measured from the inside of the external walls and should be indicated in square metres (m²)

(a) Floor area of existing/proposed structure(s):	71.7
(b) If a domestic extension is proposed, have any previous extensions/structures been erected at this location after 1 st October, 1964 (including those for which planning permission has been obtained):	Yes <input type="checkbox"/> No <input checked="" type="checkbox"/> If yes, please provide floor areas (m ²) and previous planning reference(s) where applicable:
(c) If a change of use of land and/or building(s) is proposed, please state the following: Existing/previous use Riparian area for GWS source protection	Proposed use Riparian area will remain in place underneath solar PV
(d) Are you aware of any enforcement proceedings connected to this site?	Yes <input type="checkbox"/> No <input checked="" type="checkbox"/> If yes, please state relevant reference number(s):

5. LEGAL INTEREST OF APPLICANT IN THE LAND/STRUCTURE:

Please tick appropriate box to show applicant's legal interest in the land or structure:	A. Owner <input checked="" type="checkbox"/>	B. Other <input type="checkbox"/>
Where legal interest is "Other", please state your interest in the land/structure:		
If you are not the legal owner, please state the name of the owner/s (address to be supplied at Question C in Contact Details):		

6. PROTECTED STRUCTURE DETAILS / ARCHITECTURAL CONSERVATION AREA:

Is this a Protected Structure/Proposed Protected Structure or within the curtilage of a Protected Structure: Yes <input type="checkbox"/> No <input checked="" type="checkbox"/>
If yes, has a Declaration under Section 57 of the Planning & Development Act 2000 been requested or issued for the property by the Planning Authority: Yes <input type="checkbox"/> No <input type="checkbox"/>
If yes, please state relevant reference No. _____
Is this site located within an Architectural Conservation Area (ACA), as designated in the County Development Plan? Yes <input type="checkbox"/> No <input checked="" type="checkbox"/>

7. APPROPRIATE ASSESSMENT:

Would the proposed development require an appropriate assessment because it would be likely to have a significant effect on the integrity of a European site (SAC, SPA etc)? Yes No

8. DATA PROTECTION DECLARATION:

In order for the Planning Authority to process the personal data you have provided, your consent is required. By ticking the box below, you consent to the Planning Authority processing the personal data provided by you in line with the terms of Cork County Council's Privacy Policy available at <http://www.corkcoco.ie/privacy-statement-cork-county-council> or in hardcopy from any Council office; and to having your information processed for the following purposes:

Processing of your Declaration of Exemption application by the Planning Authority

I give permission for my personal information to be processed for the purpose stated above

Signed (By Applicant Only)	Tom Jackson
Date	10/04/2024

GDPR Special Categories of data / Sensitive Personal data - Explicit Consent

Where Special Categories of personal data / sensitive personal data are provided as part of / in support of a declaration application, **explicit consent** to the processing of the special categories of data must be given by the person to whom the data refers, namely the Data Subject.

Special Categories of data / Sensitive Personal data include:

- Race
- Ethnic origin
- Political opinions
- Religion
- Philosophical beliefs
- Trade union membership
- Genetic data
- Biometric data
- Health data
- Concerning a natural person's sex life
- Sexual orientation

In order for the Planning Authority to process the sensitive personal data you have provided, your consent is required. By ticking the box below, you consent to the Planning Authority processing the personal data provided by you in line with the terms of Cork County Council's Privacy Policy available at <https://www.corkcoco.ie/privacy-statement-cork-county-council> or in hardcopy from any Council office; and to having your information processed for the following purposes:

Sensitive personal data being submitted in support of Declaration of Exemption Application

I give permission for my sensitive personal data submitted to the Planning Authority to be processed for the purpose stated above.

Signed	Tom Jackson
Date	10/04/2024

You have the right to withdraw your consent by contacting the Planning Department, Ground Floor, County Hall, Carrigrohane Road, Cork. Tel: (021) 4276891 Email: planninginfo@corkcoco.ie or by contacting the Planning Department, Norton House, Cork Road, Skibbereen, Co. Cork. Tel: (028) 40340 Email: westcorkplanninginfo@corkcoco.ie However if consent to the use of personal data is withdrawn during the declaration of exemption decision-making process this information cannot be considered as part of the decision making process. Once a decision has been made, an applicant is not entitled to withdraw consent, as the right of erasure does not apply to a situation where processing is required for compliance with a legal obligation or for the performance of a task carried out in the public interest.

Please note that all information / supporting documentation submitted will be available publicly to view at the Planning Authority offices.

8. DATA PROTECTION DECLARATION:

In order for the Planning Authority to process the personal data you have provided, your consent is required. By ticking the box below, you consent to the Planning Authority processing the personal data provided by you in line with the terms of Cork County Council's Privacy Policy available at <http://www.corkcoco.ie/privacy-statement-cork-county-council> or in hardcopy from any Council office; and to having your information processed for the following purposes:

Processing of your Declaration of Exemption application by the Planning Authority

I give permission for my personal information to be processed for the purpose stated above

Signed (By Applicant Only)	Tom Jackson
Date	28/08/24

GDPR Special Categories of data / Sensitive Personal data - Explicit Consent

Where Special Categories of personal data / sensitive personal data are provided as part of / in support of a declaration application, **explicit consent** to the processing of the special categories of data must be given by the person to whom the data refers, namely the Data Subject.

Special Categories of data / Sensitive Personal data include:

- Race
- Ethnic origin
- Political opinions
- Religion
- Philosophical beliefs
- Trade union membership
- Genetic data
- Biometric data
- Health data
- Concerning a natural person's sex life
- Sexual orientation

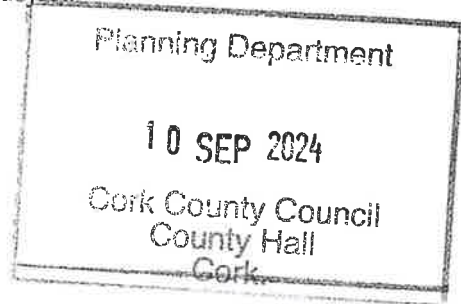

In order for the Planning Authority to process the sensitive personal data you have provided, your consent is required. By ticking the box below, you consent to the Planning Authority processing the personal data provided by you in line with the terms of Cork County Council's Privacy Policy available at <https://www.corkcoco.ie/privacy-statement-cork-county-council> or in hardcopy from any Council office; and to having your information processed for the following purposes:

Sensitive personal data being submitted in support of Declaration of Exemption Application

I give permission for my sensitive personal data submitted to the Planning Authority to be processed for the purpose stated above.

Signed	Tom Jackson
Date	28/08/24

You have the right to withdraw your consent by contacting the Planning Department, Ground Floor, County Hall, Carrigrohane Road, Cork. Tel: (021) 4276891 Email: planninginfo@corkcoco.ie or by contacting the Planning Department, Norton House, Cork Road, Skibbereen, Co. Cork. Tel: (028) 40340 Email: westcorkplanninginfo@corkcoco.ie However if consent to the use of personal data is withdrawn during the declaration of exemption decision-making process this information cannot be considered as part of the decision making process. Once a decision has been made, an applicant is not entitled to withdraw consent, as the right of erasure does not apply to a situation where processing is required for compliance with a legal obligation or for the performance of a task carried out in the public interest.

Please note that all information / supporting documentation submitted will be available publicly to view at the Planning Authority offices.

ADVISORY NOTES:

The application must be accompanied by the required fee of €80
 The application must be accompanied by a site location map which is based on the Ordnance Survey map for the area, is a scale not less than 1:1000 and it shall clearly identify the site in question.
 Sufficient information should be submitted to enable the Planning Authority to make a decision. If applicable, any plans submitted should be to scale and based on an accurate survey of the lands/structure in question.
 The application should be sent to the following address:
 The Planning Department, Cork County Council, Floor 2, Co. Hall, Carrigrohane Road, Cork, T12 R2NC; or for applications related to the Western Division, The Planning Department, Cork County Council, Norton House, Cork Road, Skibbereen, Co. Cork, P81 AT28.

- The Planning Authority may require further information to be submitted to enable the authority to issue a decision on the Declaration of Exemption application.
- The Planning Authority may request other person(s), other than the applicant; to submit information on the question which has arisen and on which the Declaration of Exemption is sought.
- Any person issued with a Declaration of Exemption may on payment to An Bord Pleanála refer a Declaration of Exemption for review by the Board within 4 weeks of the date of the issuing of the Declaration of Exemption decision.
- In the event that no Declaration of Exemption is issued by the Planning Authority, any person who made a request may on payment to the Board of such a fee as may be prescribed, refer the question for decision to the Board within 4 weeks of the date that a Declaration of Exemption was due to be issued by the Planning Authority.

The application form and advisory notes are non-statutory documents prepared by Cork County Council for the purpose of advising the type of information which is normally required to enable the Planning Authority to issue a Declaration of Exemption under Section 5. This document does not purport to be a legal interpretation of the statutory legislation nor does it state to be a legal requirement under the Planning and Development Act 2000 as amended, or Planning and Development Regulations, 2001, as amended.

9. I hereby declare that, to the best of my knowledge and belief, the information given in this form is correct, accurate and fully compliant with the Planning and Development Acts 2000, as amended and the Regulations made thereunder:

<i>Signed (Applicant or Agent as appropriate)</i>	Tom Jackson
Date	10/01/2024

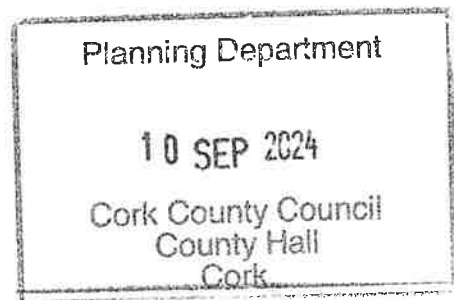

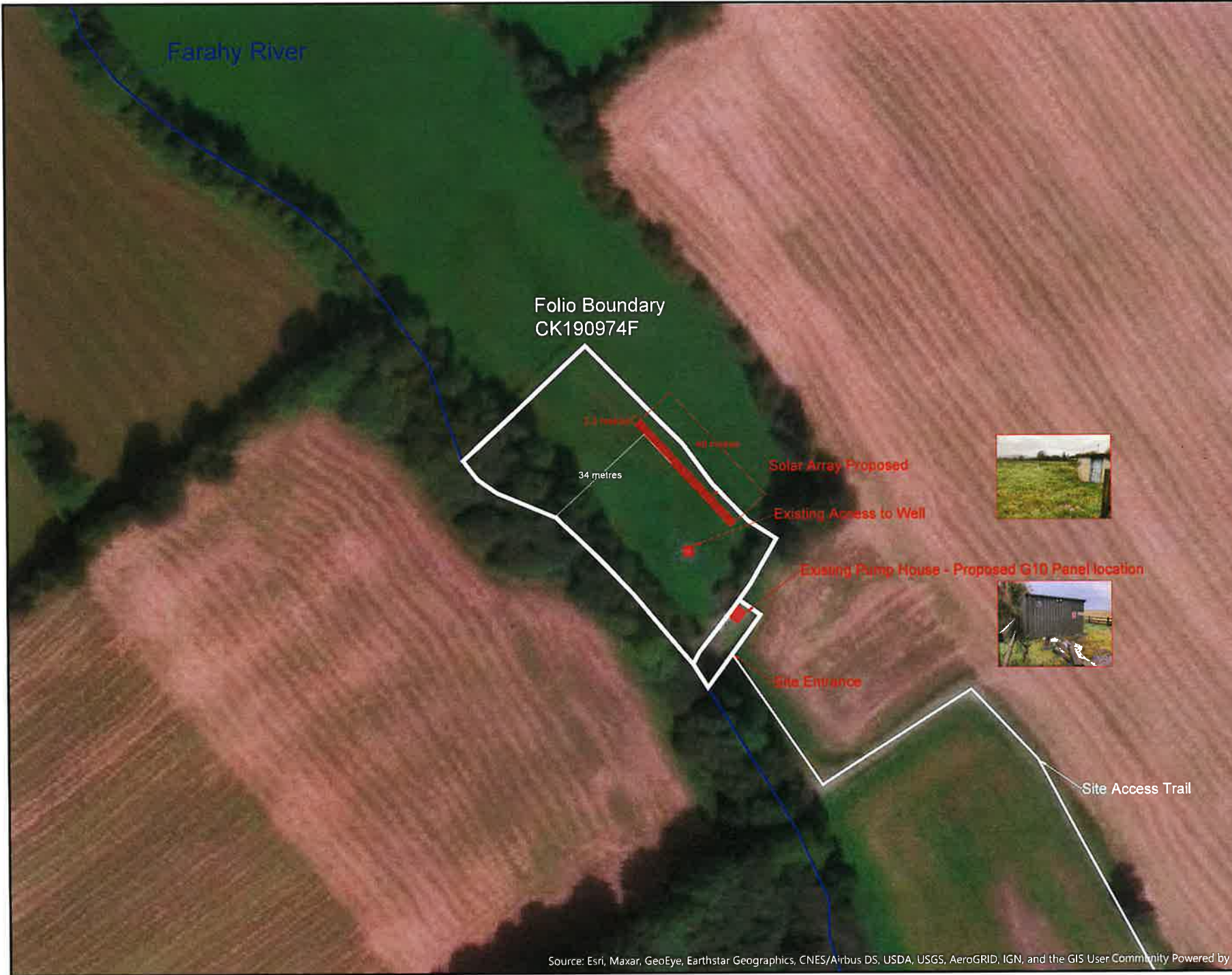

GENERAL NOTES:

Planning Department

Cork County Council
County Hall
Cork

10 SEP 2024

Rev	Drawn	Check	Issue	Date	Description



FOR INFORMATION

Drawing Title:	1:500	Drawn By:	JF
Digital Size:	A1	Date:	02.09.2024

118, Cube, Monahan Road
Cork, Co Cork
Tel: 028 22 712 11 xx
Mobile: +353 21-245 5199
Email: info@climeaction.com



Scheme Name:	NFGWS SOLAR RFQ		
Drawing Title:	NFGWS SOLAR PANELS ON FOLIO LAYOUT 1:500		
Client:	NFGWS		
Consulting Engineers:	CLIMEACTION		
Drawn By:	GWS002 Solar RFT	Scale:	FI
Drawing No.:	GWS002-SOLAR-01-001	Rev:	0



Planning Department

10 SEP 2024

Cork County Council
County Hall
Cork

GENERAL NOTES:

No.	Order	Issue	Date	Description

FOR INFORMATION

Drawing Scale:	1:2000	Drawn By:	JF
Digital Size:	A1	Date:	02.09.2024

114, Cullin, Monahan Road
Cork, Co. Cork
Postal: T12 M3XX
Phone: +353 21-245 5199
Email: info@climeaction.com

© CLIMEACTION 2024. This drawing is the property of CLIMEACTION and shall remain the property of CLIMEACTION. It is not to be used, reproduced, copied, or distributed in any form without the prior written consent of CLIMEACTION.

Scheme Name:	NFGWS SOLAR RFG
Drawing Title:	NFGWS SOLAR PANELS ON FOLIO LAYOUT 1:2000
Client:	NFGWS
Consulting Engineer:	CLIMEACTION
Revision No:	GWS002 Solar RFT
Revision Date:	FI
Drawing No:	GWS002-SOLAR-01-001
Page No.:	0

Source: Geo-Map, Google Earth, Earthstar Geographics, CNES/Airbus DS, USDA, USGS, AeroGRID, IGN, and the GIS User Community. Powered by Esri

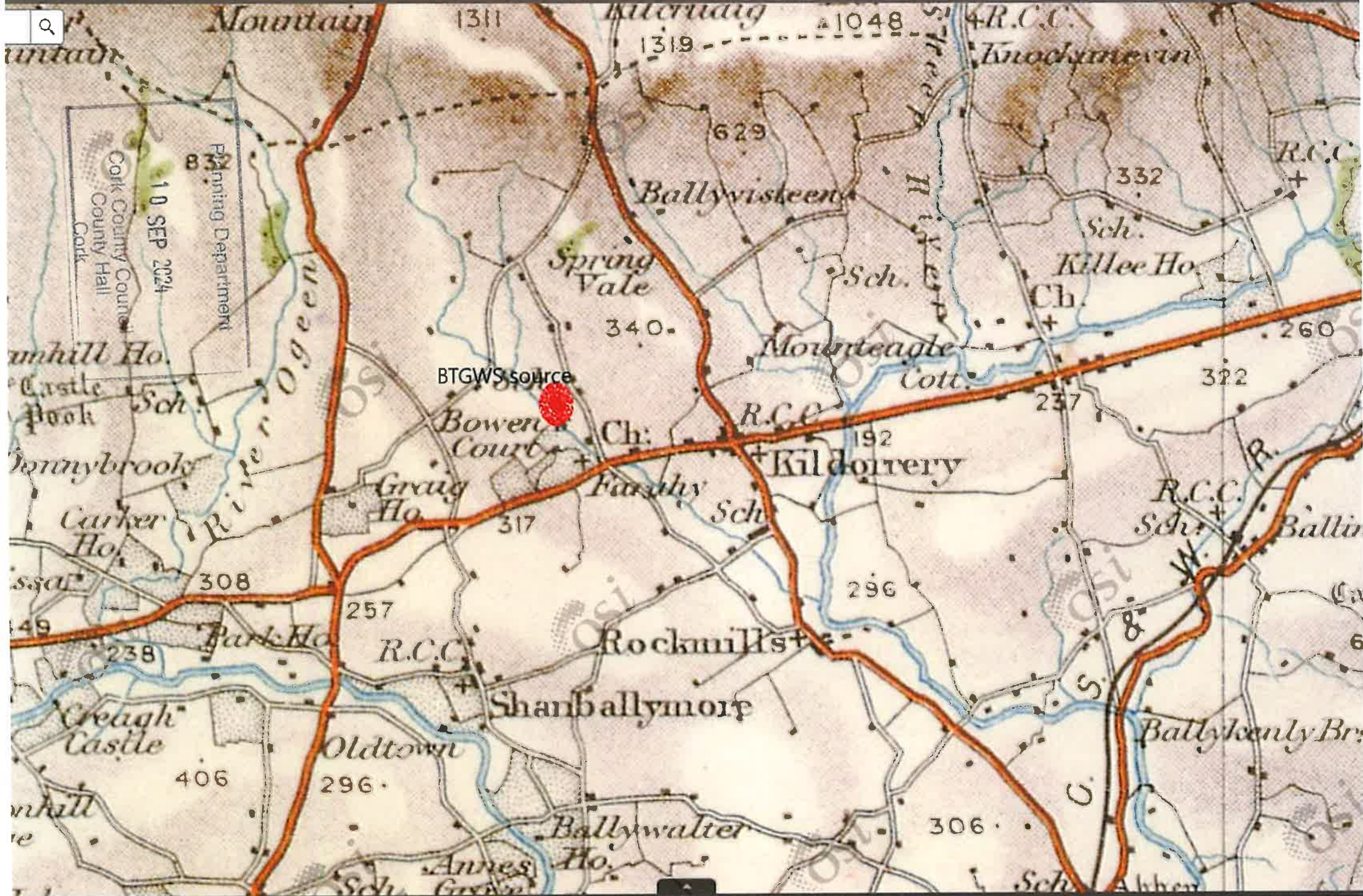

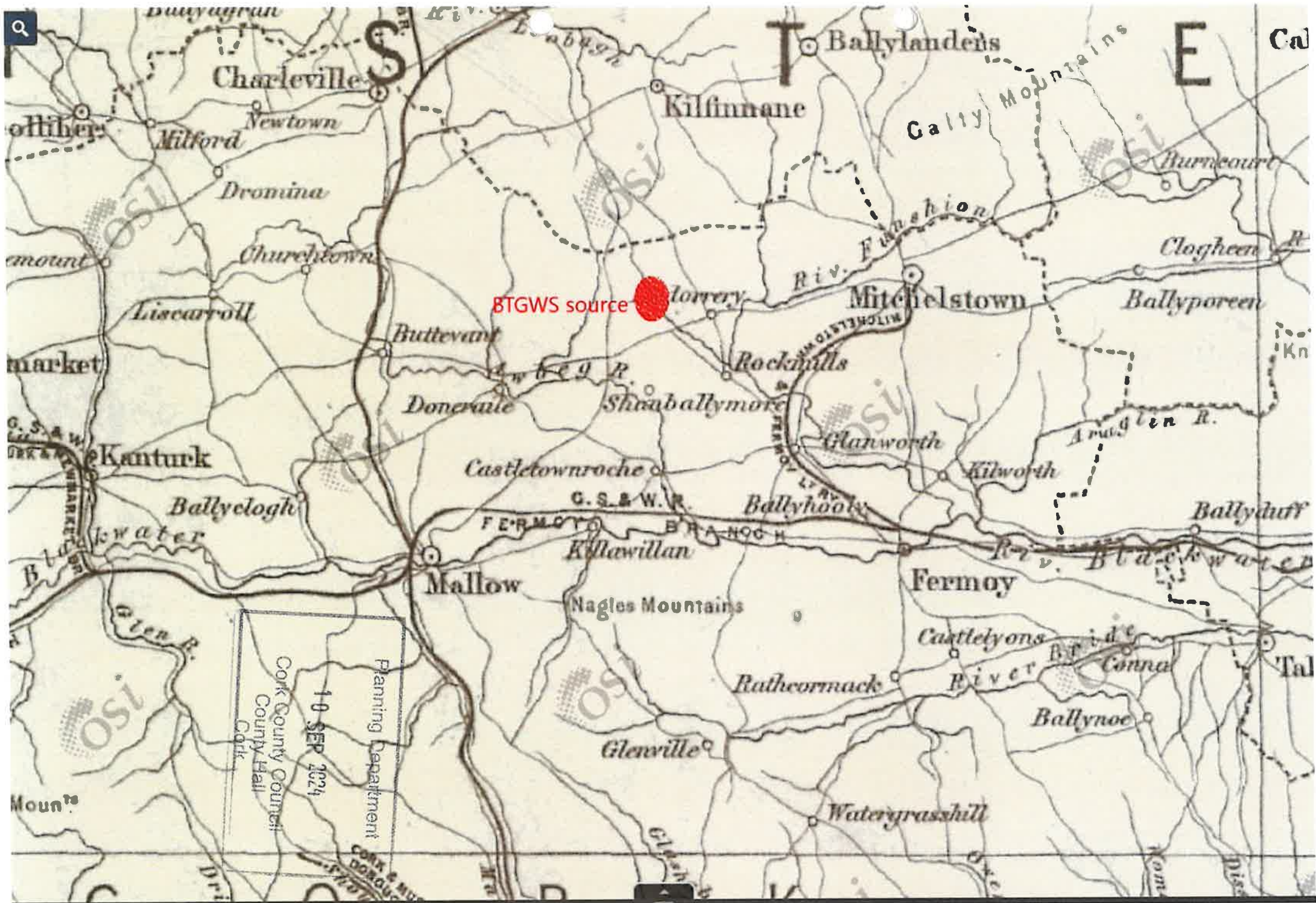

BTGWS source

Planning Department
10 SEP 2024
Cork County Council
County Hall
Cork

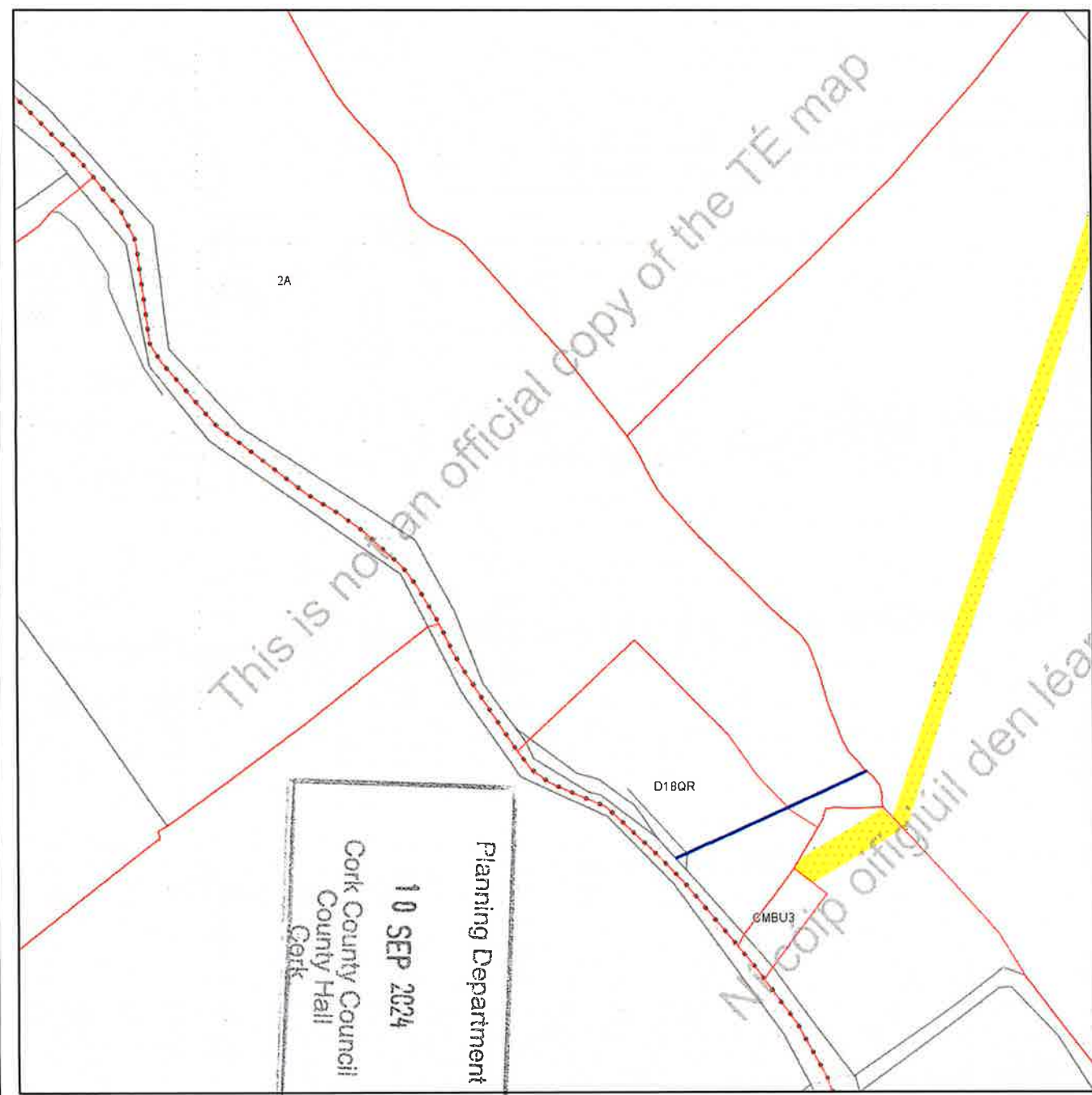

Tailte  ireann

Cl r ch n, Luach il,
Suirbh ireacht
Registration, Valuation,
Surveying

Official Tailte  ireann Registration Map

This map should be read in conjunction with the folio.

Tailte  ireann (T ) Registration mapping is based on T  Surveying mapping. Where T  Registration maps are printed at a scale that is larger than the T  Surveying scale, accuracy is limited to that of the T  Surveying map scale.

For details of the terms of use and limitations of scale, accuracy and other conditions relating to T  Registration maps, see www.tailte.ie.

This map incorporates T  Surveying map data under a licence from T . Copyright   Tailte  ireann and Government of Ireland.

- (centre-line of parcel(s) edged)
 - Freehold
 - Leasehold
 - SubLeasehold
 - 'S' Register
- (see Section 8(b)(II) of Registration of Title Act 1964 and Rule 224 & 225 Land Registration Rules 1972 - 2010).

- Burdens** (may not all be represented on map)
- Right of Way / Wayleave
 - Turbarry
 - Pipellne
 - o Well
 - Pump
 - Septic Tank
 - ∇ Soak Pit
- A full list of burdens and their symbology can be found at: www.landdirect.ie

Tailte  ireann Registration operates a non-conclusive boundary system. The T  Registration map identifies properties not boundaries meaning neither the description of land in a folio nor its identification by reference to a T  Registration map is conclusive as to the boundaries or extent.

(see Section 85 of the Registration of Title Act, 1964), As Inserted by Section 62 of the Registration of Deed and Title Act 2006.

Planning Department
 10 SEP 2024
 Cork County Council
 County Hall
 Cork





Inside Pump House View



INSIDE PUMP HOUSE VIEW

V.A.T. No.: 5197768N

DECLAN MOLAN
Solicitors

Your Ref:

Our Ref:

E-Mail: office@molansolicitors.ie

DM/EOB/BAL007/0001/8319

Date:
21 Nov 2023

Tom Jackson,
Quitrent,
Kildorrery,
County Cork.

RE: PURCHASE OF PLOT BY GROUP WATER SCHEME

Dear Tom,

I have today received confirmation from the Land Registry that the plot purchased by the Group Water Scheme has now been registered under Folio CK190974F.

This matter is now completed.

Yours sincerely,

Declan Molan

Planning Department

10 SEP 2024

Cork County Council
County Hall
Cork

Tailte Éireann



DECLAN MOLAN SOLICITORS
7 BALDWIN STREET
MITCHELSTOWN
CO. CORK

Our Reference: D2022LR071799Y
Your Reference: DM/EOB/BAL007/0001
Folio: CK48956F
New Folio Number: CK190974F
Applicant: BALLINGUYROE & TANKARDSTOWN GROUP WATERSCHHEME CO-OPERATIVE SOCIETY LIMITED

Notice of Completion

Dear Sir/Madam,

We are pleased to inform you that the above application has been completed. The returnable documents (if any) are listed in the schedule below.

Copy Folios and Copy Folio/Title Plans (if requested) will issue separately.

Yours faithfully,

Lynn Holohan
Southern Region Mapping Casework (Waterford)

20th November 2023

SCHEDULE

1. Form 17

Planning Department
10 SEP 2024
Cork County Council
County Hall
Cork